



**pagolux® Interieur**  
metal production







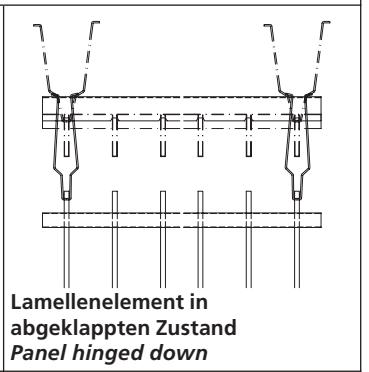
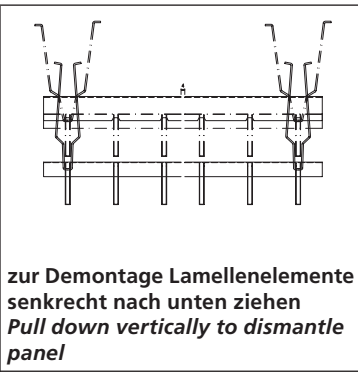
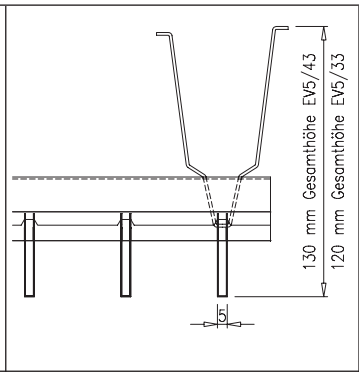
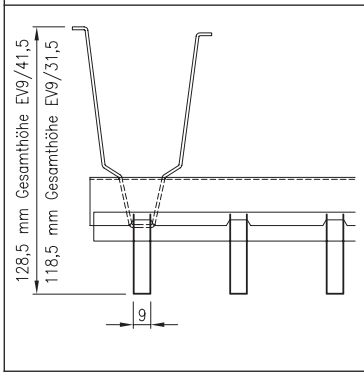
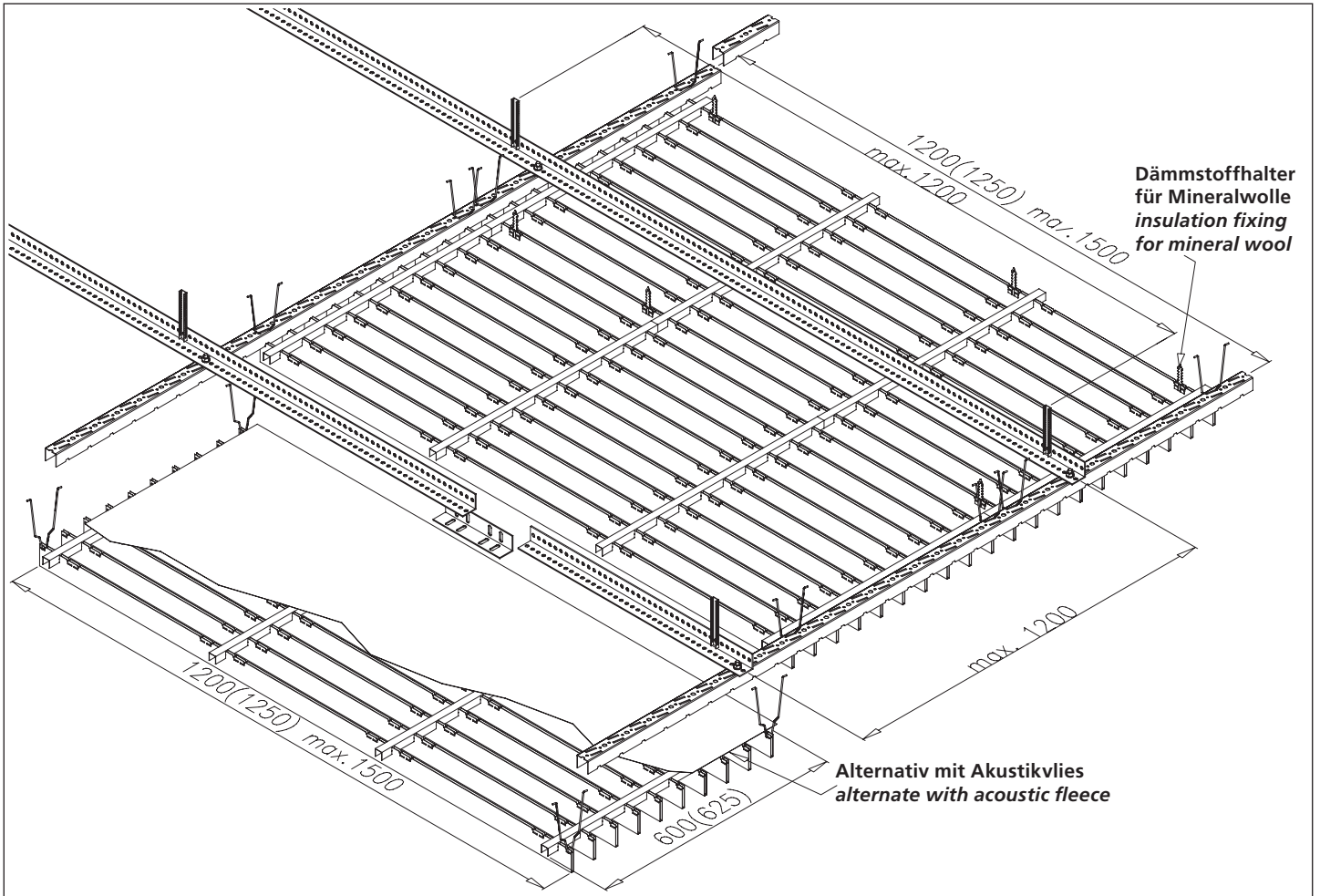

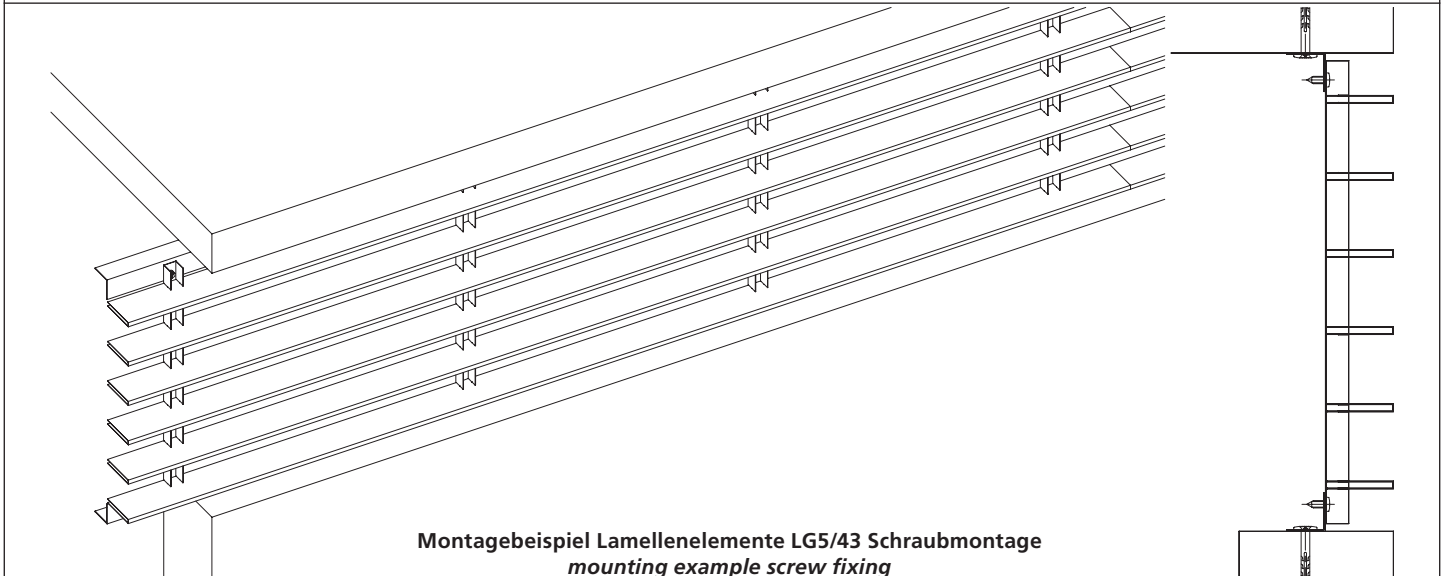

**Lamellensystem Evolution Vario**  
**Typ EV5/EV9**

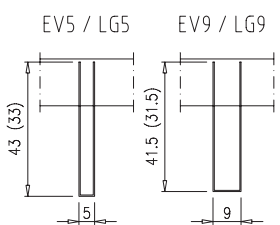
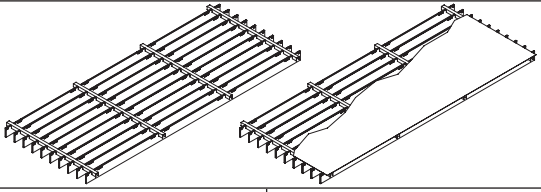
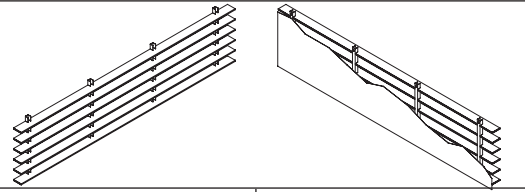
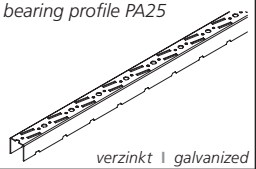
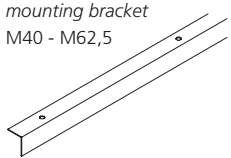
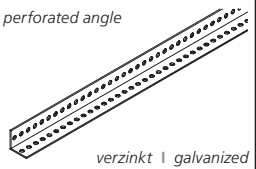
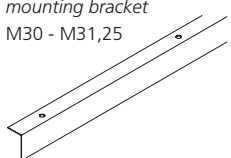
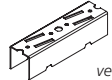
*linear grid system Evolution Vario*  
*Type EV5 / EV9*



Pagolux® Lamellensystem Evolution Vario EV5 | EV9 LG  
Pagolux® Linear grid Evolution Vario EV5 | EV9 LG

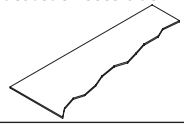
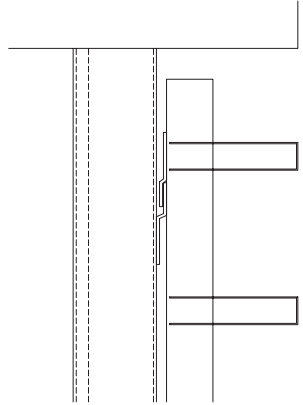

		Pagolux® Lamellensystem Evolution Vario EV5   EV9 FA Pagolux® Linear grid Evolution Vario EV5   EV9 FA				Pagolux® Lamellensystem Evolution Vario EV5   EV9 LG Pagolux® Linear grid Evolution Vario EV5   EV9 LG																			
																									
Typ I type		Lamellen   Linear grid   EV5 LH 33/45		Lamellen   Linear grid   EV9 LH 31,5/41,5		Lamellen   Linear grid   EV5 LH 33/45		Lamellen   Linear grid   EV9 LH 31,5/41,5																	
Modul (mm)   Module (mm)		30	31,25	40	50	56	62,5	30	31,25	40	50	56	62,5	30	31,25	40	50	56	62,5	30	31,25	40	50	56	62,5
ca. Gew. kg/m²   Approx. weight kg/m²		Abhängig vom Modul depending on module				Abhängig vom Modul depending on module				Abhängig vom Modul depending on module				Abhängig vom Modul depending on module											
Bestell Nr.   Order-No.		3,9917-EV5/33		3,9918-EV5/43		3,9919-EV9/31,5		3,9920-EV9/41,5		3,9917-EV5/33		3,9918-EV5/43		3,9919-EV9/31,5		3,9920-EV9/41,5									
ca. Raster/m²   Approx. grid/m²		1,39 Stück   pcs		1,28 Stück   pcs		1,39 Stück   pcs		1,28 Stück   pcs		Höhen Modulabhängig ab 90 mm height depending on module from 90 mm															
Abm. (mm) L/B/H   measur. L/B/H (mm)		600 x 1200 mm		625 x 1250 mm		600 x 1200 mm		625 x 1250 mm		Längen bis max. 2500 mm   lengths up to 2500 mm															
Verp. je Karton   Packing unit/carton		6 Stück   pcs		5 Stück   pcs		6 Stück   pcs		5 Stück   pcs		Abhängig von Modul und Abmessung depending on module and dimension															
Pos.	Zubehör   Accessories	Bestell Nr.   Order-No. ca. Bedarf m² Achse 600 x 1200 Need/m² Axis 600 x 1200				Bestell Nr.   Order-No. ca. Bedarf m² Achse 625 x 1250 Need/m² Axis 625 x 1250				Pos.	Zubehör   Accessories	Bestell Nr.   Order-No. ca. Bedarf m²   Need/m²													
1	 Tragprofil PA-25 bearing profile PA25 <i>verzinkt   galvanized</i>	3,7896- Länge   length: 3000 mm ca. 0,83 m				3,7896- Länge   length: 3000 mm ca. 0,8 m				1	 Montagewinkel 25 x 30 mounting bracket M40 - M62,5	3,7502-L25x30 Länge   length: 2500 mm													
2	 Rostwinkel perforated angle <i>verzinkt   galvanized</i>	3,7874-0100 Länge   length: 4000 mm ca. 0,83 m				3,7874-0100 Länge   length: 4000 mm ca. 0,8 m				2	 Montagewinkel 25 x 40 mounting bracket M30 - M31,25	3,7502-L25x40 Länge   length: 2500 mm													
3	 Tragprofilverbinder Connector for PA25 <i>verzinkt   galvanized</i>	3,7897- ca. 0,3 Stück   ca. 0,3 pcs				3,7897- ca. 0,3 Stück   ca. 0,3 pcs				3	 Lamellenführung LG5 connector LG5	3,7926-LG5 Länge   length: 75 mm													
4	 Verbinder Rostwinkel Connector for perforated angle <i>verzinkt   galvanized</i>	3,7875-0100 Länge   length: 150 mm ca. 0,21 Stück   ca. 0,21 pcs				3,7875-0100 Länge   length: 150 mm ca. 0,21 Stück   ca. 0,21 pcs				4	 Lamellenführung LG9 connector LG9	3,7926-LG9 Länge   length: 75 mm													
5	 Montagefeder mounting spring <i>verzinkt   galvanized</i>	3,7898-0100 4 Stück - Element   4 pcs - Element				3,7898-0100 4 Stück - Element   4 pcs - Element				5	 Akustikvlies Schwarz acoustic fleece black	3,7270-R6/60													
6	 Nonius Unterteil Nonius hanger subpart	3,7881-0200 Länge   length: 150 mm ca. 1 Stück   ca. 1 pcs				3,7881-0200 Länge   length: 150 mm ca. 1 Stück   ca. 1 pcs				Sonderzubehör z.B. für Einhängmontage auf Anfrage optional accessory on request															
7	 Akustikvlies Schwarz acoustic fleece black	3,7270-R6/60				3,7270-R6/60																			
8	 Dämmstoffhalter insulation fixing	3,7827-0200				3,7827-0200																			



## Systembeschreibung

### PAGOLUX® Lamellensystem Evolution Vario EV5/EV9 FA

Pagolux® Lamellensystem Evolution Vario FA wird aus 0,4 mm bandlackiertem Aluminiumblech hergestellt. Die Abmessung der einzelnen Lamellenelemente ist 600 x 1.200 (bzw. 625 x 1.250 mm.) Die Lamelle ist 33 / 43 oder 31,5 / 41,5 mm hoch. Die Modulgröße ist wahlweise 30, 40, 50, oder 60 mm (Achismaß 1.200 mm), 31,25, oder 62,5 mm (Achismaß 1.250 mm). Die Lamellenelemente Evolution Vario FA haben spezielle Justier- und Ausstanzungen zur Federanhangung. Eine neue filigrane Optik zeichnet dieses Lamellensystem aus.

**Brandschutzklassifikation:** A2-s1, d0

## Abhängung / Montage

Von der Rohdecke ist mittels zugelassener Dübel, Schrauben, etc. im statisch erforderlichen Abstand von 1200 mm ein Konterrost bestehend aus Rostwinkeln, systemeigenen Trageprofilen PA 25, Längsverbindern und Kombiverbindern mit Noniusabhängern oder Gewindestangen abzuhängen und lot- und fluchtgerecht auszurichten. Das formgelochte U-Trageprofil wird passend zur Längsachse der Lamellenelemente unter den Rostwinkel geschraubt. Anschließend werden die Elemente mit 4 Haltefedern bestückt und über diese in das Trageprofil PA 25 eingeklippt.

## Anschlüsse

Anschlüsse an Wände etc. können als offene Schattenfuge, oder mit einem systemkonformen C-Profil / Wandwinkel in Systemfarbe ausgebildet werden. Anschnitte bzw. Ausschnitte der Lamellenelemente sind je nach Geometrie der Räumlichkeiten werkseitig, oder bauseits möglich. Der Einbau von Leuchten ist, abhängig von der Leuchtenform, durch Ausschnitte in den Rasterelementen oder zusätzlichen, systemeigenen Modulplatten (runde Downlights) durchzuführen. Grundsätzlich ist das Gewicht der Leuchten abzufangen.

## Eigenschaften

- stabil durch separate UK
- unempfindliche Oberfläche
- Demontage jedes Lamellenelementes nach unten

## Design

Filigran und modern

### PAGOLUX® Lamellensystem Evolution Vario EV5/EV9 LG

Pagolux® Lamellensystem Evolution Vario LG wird aus 0,4 mm bandlackiertem Aluminiumblech hergestellt. Die Abmessung der einzelnen Lamellenelemente ist modulabhängig Höhen ab 90 mm Längen bis max.2500 mm.

Lamellenhöhen EV5 33 / 43, EV9 31,5 / 41,5 mm.  
Lamellenabstand EV5 ab 25 mm EV9 ab 30 mm

## Montage

Die Befestigung der Lamellenelemente erfolgt durch Verschrauben an den ober / unterhalb der Elemente mittels zugelassener Dübel, Schrauben, etc fluchtgerecht angebrachten Montagewinkeln siehe Montagebeispiel Lamellenelemente LG5/LG9 Seite 2.

Sonderausführung als Einhängeelemente oder mit Rahmen auf Anfrage

## Eigenschaften

- stabil durch separate UK
- unempfindliche Oberfläche

## Design

Filigran und modern

Wir beraten Sie gerne individuell auf Ihr Objekt bezogen.

Technische Änderungen vorbehalten.

pagolux® - eingetragenes Warenzeichen der Pagolux Interieur, Xanten

## System Description

### pagolux® linear grid system Evolution Vario EV5/EV9 FA

*Pagolux® linear grid system Evolution Vario FA is made of 0,4 mm coil-coated aluminum sheets. The dimensions of the single grids are 600 x 1200 or 625 x 1250 mm. The lamella is 33/43 or 31,5/41,5 mm high. The module size amounts optionally 30,40,50 or 60 mm (axis 1200 mm), 31,5 or 62,5 (axis 1250 mm).*

*The panels are equipped with special adjustable and slot punchings for suspension with mounting springs.*

*A new filigree design characterizes this system.*

**Fire classification:** A2-s1, d0

## Assembly / Suspension

*From the raw ceiling a cross grid consisting of perforated angles, bearing profiles PA25, straight connectors and combi-connectors has to be depended by means of admitted dowels, bolts etc. with a necessary spacing for structural stability of 1200 mm. The perforated bearing profile PA25 has to be screwed under the perforated angle, fitting to the longitudinal axis of the elements.*

*Afterwards the single elements have to be equipped with 4 mounting springs and have to be clipped into the bearing profile PA25.*

## Fittings

*Fittings to walls etc. can be constructed as an opened shadow gap with native C-profiles in colour of the system. Cuts of the grids, depending on the room geometry, are possible on site as well as factory-made.*

*The installation of luminaires depends on the form of the light and can be realized by cut outs.*

*Basically the weight of the lights has to be checked.*

## Characteristics

- sturdy because of separate substructure
- insensitive surface
- disassembly of every grid possible

## Design

Filigran and modern

### pagolux® linear grid system Evolution Vario EV5/EV9 LG

*Pagolux® linear grid system Evolution Vario LG is made of 0,4 mm coil-coated aluminum sheets. The dimensions of the single grids depend on the module. Heights from 90 mm, lengths up to 2500 mm*

*Height Lamella EV5 33 / 43, EV9 31,5 / 41,5 mm  
Axis Lamella EV5 from 25 mm, EV9 from 30 mm*

## Assembly

*The linear grids have to be fixed by screwing them down on mounting angles by means of admitted dowels, bolts etc. See mounting example page 2.*

*Special constructions as hook-in element or with frame on request*

## Characteristics

- sturdy because of separate substructure
- insensitive surface

## Design

Filigran and modern

*We'll be pleased to advise you individually for your object.*

*Technical details are subject to change without notice.*

*pagolux® - registered trademark of Pagolux Interieur, Xanten*